



Add a sophisticated touch to your facility. Brushed Aluminium Clocks offer an upscale, high tech look that will enhance any décor.



Features:

- Brushed Aluminium Casing
- Glass Lens
- Sophisticated Metallic Appearance
- Battery (2 D-Cell)
- Automatically Adjusts for DST
- Maintenance Free

Clock Styles

Dial Options



16" (40.64cm) Double Sided Ceiling Mount
Part # 520016 - Battery



16" (40.64cm) Double Sided Wall Mount
Part # 520026 - Battery



13" (33.02cm) shown above
Part # 510016 - Battery



13" (33.02cm)
Part # 510006L



LCD Display
(Month, Date and Day)

16" (40.64cm)
Part # 510006 - Battery



Standard Arabic 12/60 **Part # SA60**



Classic Arabic **Part # CA00**



Standard Military 12/24 **Part # SM24**

Additional Custom Logo Designs Available

13" (33.02cm) Brushed Aluminium Clock Specifications

- Brushed Aluminium Cases
- Glass Lens
- Sophisticated Metallic Appearance
- Battery (2 D-Cell)
- Battery Life Expectancy - 5 years

Rear Case Diameter: 13.125" (33.3375cm)
 Front Case Diameter: 13" (33.02cm)
 Dial Graphics Diameter: 9.75" (24.765cm)
 Edge Thickness: 2.5" (6.35cm)

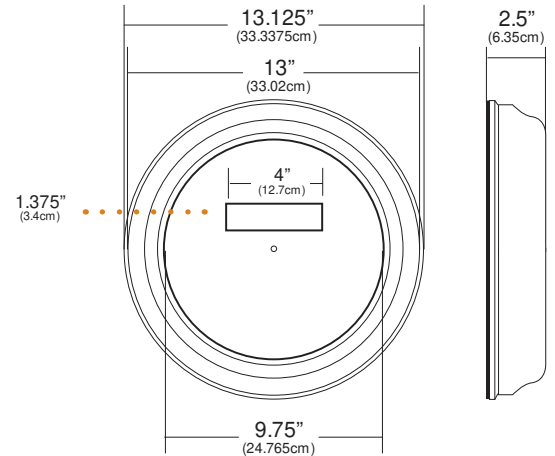

16" (40.64cm) Brushed Aluminium Clock Specifications

- Brushed Aluminium Cases
- Glass Lens
- Sophisticated Metallic Appearance
- Battery (2 D-Cell)
- Battery Life Expectancy - 5 years

Rear Case Diameter: 16" (40.64cm)
 Front Case Diameter: 15.75" (40.005cm)
 Dial Graphics Diameter: 12.25" (31.115cm)
 Edge Thickness: 2.75" (6.985cm)
 Ceiling and Side Mount Dimensions: 3"H x 4.5"D (7.62cm H x 11.43cm D)

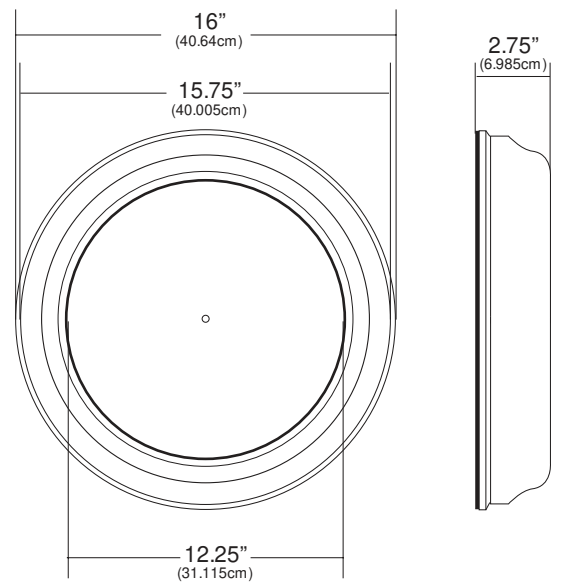

13" (33.02cm) and 16" (40.64cm) Rear View / Mount Specifications

