



RGB Technology[®]
MODERN TECHNOLOGIES

OPERATION AND MAINTENANCE MANUAL

FLUSH MOUNTED CLOCK ZA5

Product code:
301-17-CX



Distributed by: Innovation Wireless Ltd - 08000 248 091 - info@innovation-wireless.co.uk



Table of contents

1	Manufacturer	3
2	Specifications	3
3	Transport and storage	3
4	Device construction	3
4.1	List of cables	3
4.2	ZA5 clocks construction	4
4.3	ZA5 device dimensions	4
5	Device installation	5
5.1	ZA5 application	5
5.2	ZA5 configuration	5
5.2.1	Device configuration using the remote control	5
5.2.2	Device configuration through the built-in website - Web panel	6
6	Control module	7
7	Description of the control module connectors	7
8	Device accuracy	8
9	Automatic device brightness control	8
10	Additional options	8
10.1	Alternative power methods – PoE (Power over Ethernet)	8
10.2	Cooperation with other clocks	8
10.3	GPS module	8
10.4	Temperature probe	9
10.5	RS485 wired remote control - for flush mounting	9
10.6	Wireless IR remote control	10
11	Initial start-up	10
12	Disposal and recycling	10
12.1	Packaging material recycling	10
12.2	Device disposal	10
13	Most common installation errors	10

1 Manufacturer

RGB Technology Sp. z o. o. (RGB Technology Ltd.)

2 Specifications

Table 1

Device dimensions (WxHxD) [mm]:	358 x 150 x 45
Display format:	HH:MM:SS
Acceptable input voltage range (long-term) :	100 ÷ 240 VAC
Acceptable input voltage range (short-term):	85 ÷ 264 VAC
Acceptable input voltage frequency range:	47 ÷ 63 Hz
Digit height [mm]:	50
Device weight:	2 kg
Ingress protection rating ¹ - IP:	66
Average device power consumption:	5W
Operating temperature (ambient):	-25°C ÷ 45°C
Operating temperature (device surface):	-25°C ÷ 60°C

Available LED colors:

- red
- green
- blue
- yellow
- amber
- white

3 Transport and storage

The device is sensitive to mechanical damage. It should be ensured that it is properly secured for transport so as to eliminate any damage. It is forbidden to transport the device components separately in a collective package – each item must be packed individually and cannot 'bump' during transportation.

Due to the protective packaging, the device should be stored in the temperature -20°C ÷ +60°C at the humidity below 99% RH.

4 Device construction

ZA5 in the flush-mounted variant has a housing made of stainless steel. The LED module is protected from the front with a glued glass, thanks to which - after proper installation - the device is characterized by IP 66 protection level.

4.1 List of cables

1. 230V variant:
 - 2m long mains power cord (3x0.75mm²) terminated with a plug,
 - 2m long LAN cable terminated with a RJ-45 plug (LAN variant only).
2. PoE+ variant:
 - 2m long LAN cable terminated with a RJ-45 plug.

¹ The degree of protection based on the EN 60529 standard

4.2 ZA5 clocks construction

The figure shows the ZA5 device construction².

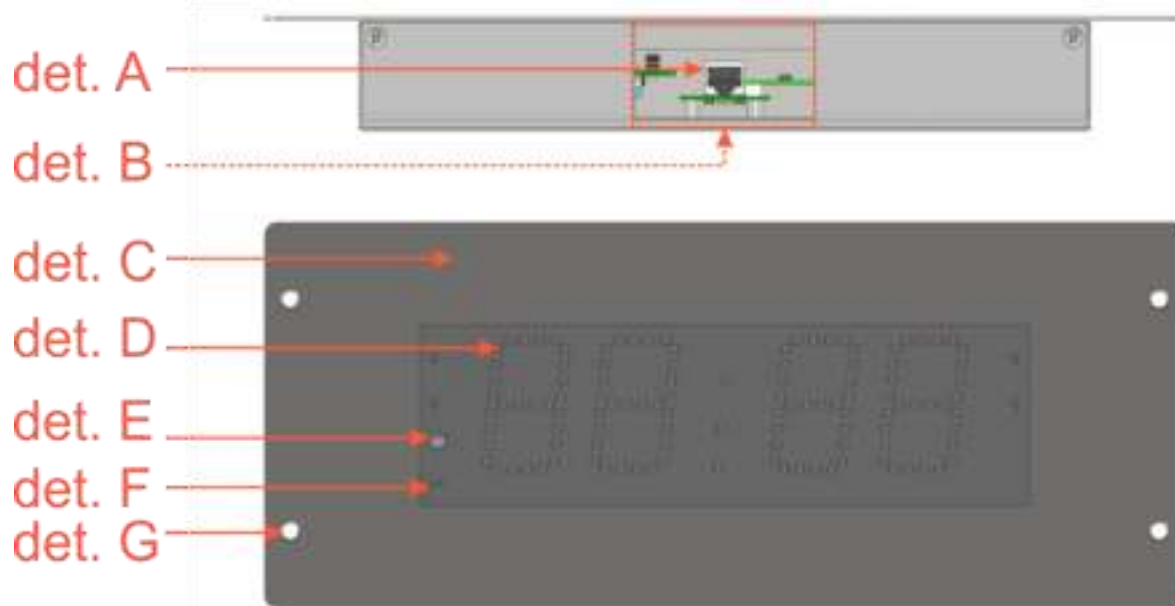

Fig. 1

det. A – LAN connector (only for variants with LAN option); det. B – place where the cables are led out; det. C – device front; det. D – glass viewfinder; det. E – lighting sensor; det. F – IR sensor; det. G – mounting holes.

4.3 ZA5 device dimensions

The dimensions given in all figures are in [mm]. The housing has 4 mounting holes with a diameter of 6.2 mm.

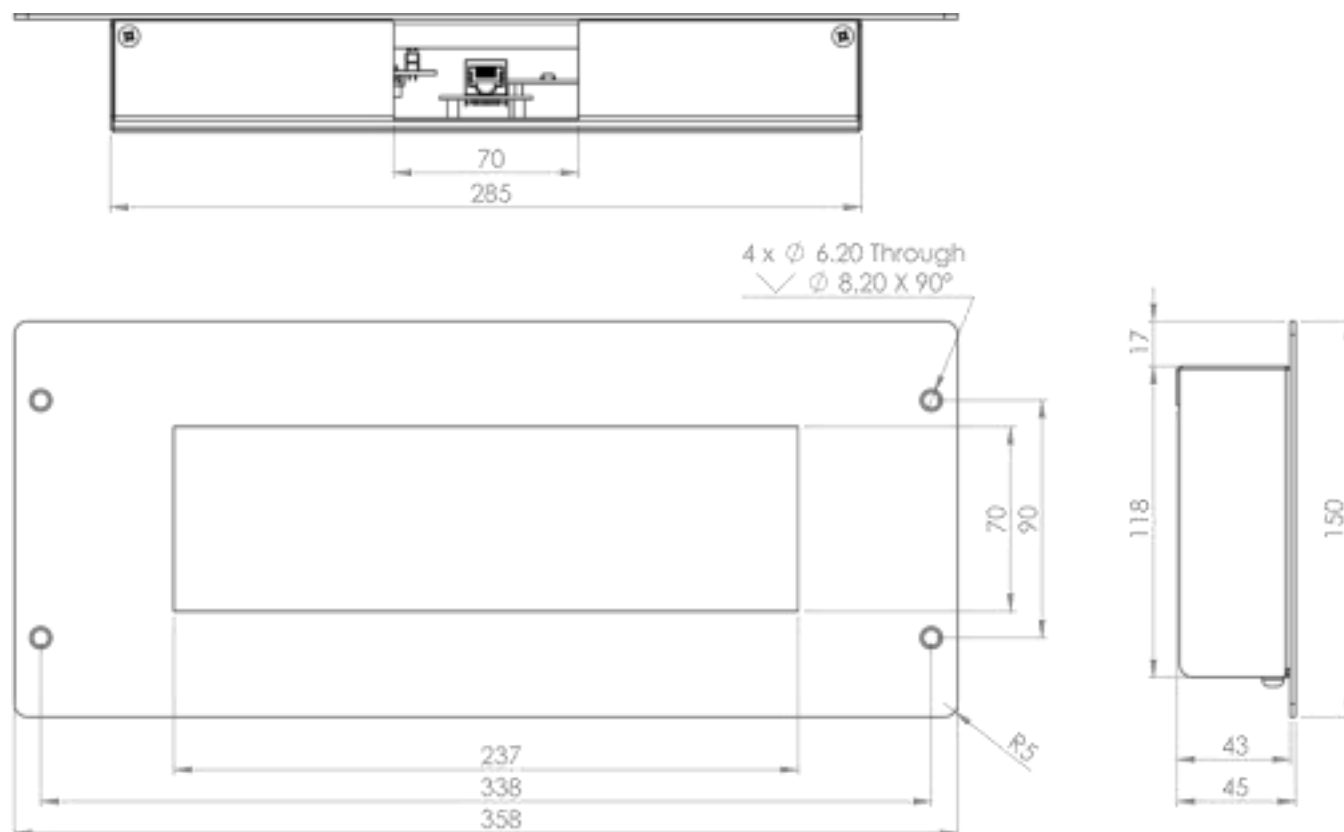

Fig. 2

² Explanatory figure.

5 Device installation

Proper installation consists in placing the device in a prepared socket in the wall and screwing the housing using 4 mounting holes prepared by the manufacturer.

NOTICE!

Before any installation or maintenance operations refer to the manual supplied by the manufacturer. Improper connection to the mains power supply, incautious device installation or improper use may cause the property damage, loss of health or death from electric shock! In addition, any failure to follow the manufacturer's instructions may void your warranty.

NOTICE!

Keep in mind that all the components should be mounted with the cables facing down.

NOTICE!

It is forbidden to make any additional mounting points or any holes in the device assembly components.

5.1 ZA5 application

The ZA5 device is designed to display time, date and optionally temperature. In addition, the clock allows you to change the operating mode to a stopwatch, timer or count-up-and-down mode. Correct configuration is necessary for the device to function properly.

5.2 ZA5 configuration

The configuration process consists in personalizing the device by the user. As standard, the device is configured via LAN network connection, and optionally it is also possible to use an infrared remote control sold separately.

5.2.1 Device configuration using the remote control

The method of configuring the clock using the remote control³ consists in selecting the appropriate options from the user menu. Fig. 3 shows the remote control with an explanation of the functions of individual buttons. The user menu is entered using the MENU button. Navigating and modifying individual parameters is done using the ↑, ↓, ← and → buttons.

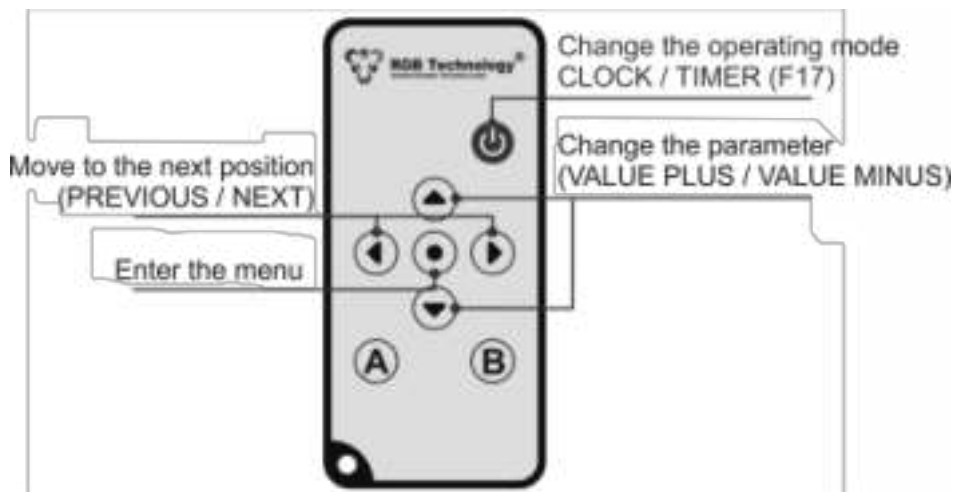

Fig. 3

³ The remote control is an optional accessory

The structure of the main menu is as follows:

Menu position	Function description
F1	Manual settings of the time and date
F2	Configuration of the presented parameters
F3	Configuration of the date and time format
F4	Configuration of the time synchronization and the Master Mode
F5	Configuration of the display brightness
F6	Configuration of the alarms
F7	Configuration of the ECO mode
F8	Configuration of the display font
F9	Restoration of the default settings
F10	Configuration of the temperature and offset unit
F11	Configuration of the display synchronization
F12	Displaying information about the signal strength or the GPS module disconnection
F13	Regional settings, i.e. location, time zones, daylight saving time
F14	Function of a stopwatch / timer / long-term counter / break
F15	Configuration of the device network settings (static IP / DHCP addressing)
F16	Configuration of the RS-485 interface mode (of the mode display synchronization)
F17	Configuration of the quick-access counter
F18	Configuration of blocking the restoration of the default settings by shorting the GPS pin to GND

5.2.2 Device configuration through the built-in website - Web panel

In order to connect to the clock, you must first configure the network card of the computer to which it is connected. The instruction for the correct configuration of the network card is available for download at <http://rgbtechnology.pl/soft/>. After the correct configuration of the network connection, you can, via a web browser, connect to the built-in website (Web panel), where you can personalize the device. The following tabs are available on the built-in clock website:

- TIME -> tab for configuring the time-related parameters;
- DISPLAY -> tab for configuring the device display parameters;
- ALARMS -> tab for configuring the alarms-related parameters (option available for the version with a sounder);
- ADVANCED -> tab for configuring the device advanced parameters;
- STATUS -> tab for reading the device status;
- FIRMWARE -> tab for reading the software version, device type and software update;
- TIMERS -> tab for changing the device operating mode from the clock to the stopwatch or time counter.

A detailed description of the configuration is available in the device operation manual named instr_hardware_048.

6 Control module

The control module (Fig. 4) enables the operation of peripheral devices and, thanks to the supercapacitor, ensures correct time counting in the absence of external power supply.

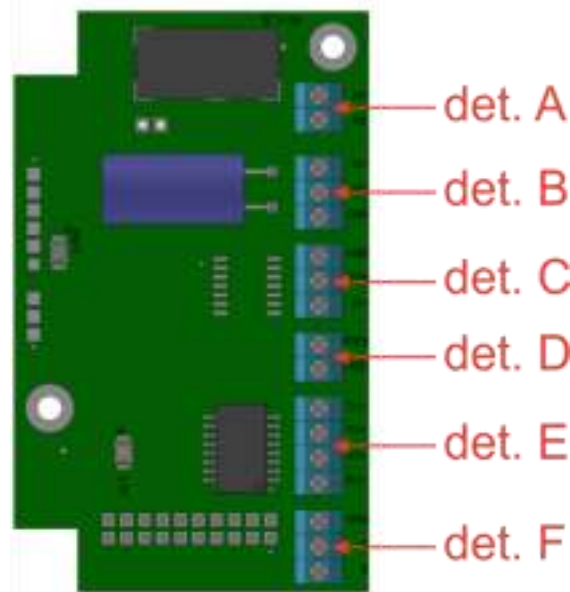

det. A – relay connector; det. B – GPS connector; det. C – temperature probe connector; det. D – PoE output; det. E – LAN connector; det. F – RS-485 connector.

Fig. 4

7 Description of the control module connectors

Table 2

	Marking	Function	Notes	Color of the connected core
STANDARD	RA	Relay (alarm signaling device)	Field not used in this model	-
	RB			-
	5V	GPS module power supply	GPS and temperature probe power supply	red
	GPS	GPS module signal	-	orange
	GND	System mass	-	black
	5V	Temperature probe power supply	GPS and temperature probe power supply	red
	TEM	Temperature probe signal	-	orange
	GND	System mass	-	black
	TX+	Ethernet	Pin no. 1 of the RJ-45 plug	orange-and-white
	TX-		Pin no. 2 of the RJ-45 plug	orange
	RX+		Pin no. 3 of the RJ-45 plug	green-and-white
	RX-		Pin no. 6 of the RJ-45 plug	green
	POE1	PoE output lines (Power over Ethernet)	IEEE 802.3at Mode A (Endspan)	red
	POE2			black
	GND	GND line of the RS-485 system	-	black
	A	RS-485 signal line	RS-485 interface non-inverting line	red
B	RS-485 signal line	RS-485 interface inverting line	orange	

8 Device accuracy

The common time standard for the device is a quartz crystal oscillator of the built-in RTC clock. The declared accuracy of this clock with a stable power supply and an operating temperature of 25°C is +/- 1 minute per month.

In order to eliminate the RTC clock error (acceleration or delay), the accuracy of the device can be increased by synchronizing with another time standard. The deviation from the standard declared in Table 2 defines a one-time and non-cumulative indication error.

Table 3

Standard type	Communication method	Deviation from the standard
NTP time server	LAN	server dependent, maximum: +/- 20 ms
GPS system	GM-2 GPS module	strong and stable signal: +/- 20 ms weak signal: +/- 100 ms
Master clock	LAN	master clock dependent

Notice! In the case of the first synchronization or resumption of synchronization (e.g. after signal loss), the device regains full accuracy after 40 to 80 seconds.

9 Automatic device brightness control

A brightness sensor is included as standard. The device has the ability to adjust the brightness of the clock display to the ambient lighting conditions.

10 Additional options

10.1 Alternative power methods – PoE (Power over Ethernet)

In this variant, the device is powered via the LAN connector. To power the device in this variant, a power supply device compliant with the IEEE 802.3at Mode A (Endspan) standard is required.

10.2 Cooperation with other clocks

The device in the variant with LAN support has the ability to cooperate with other clocks via the network. In this system, the master clock is the time standard for the slave clocks and controls the information displayed by them. Thanks to this solution, all clocks indicate the same time and type of information, e.g. they display the temperature at the same time. Different models of clocks produced by RGB Technology can cooperate with each other.



Fig. 5

10.3 GPS module

Optionally, the device may be equipped with an external GPS module (Fig. 6). The properly configured clock equipped with the GPS module synchronizes with the time received from satellites. The standard length of the GPS module cable is 10m. A detailed description of the module is available in the GPS module technical and operational (DTR) documentation.



Fig. 6

10.4 Temperature probe

Optionally, the device can be equipped with a temperature probe (Fig. 7), which allows you to measure and display the temperature in degrees Celsius or Fahrenheit. The following signal cable length variants are available: 0.5m, 2m, 5m, 15m and 50m. A detailed description of the temperature probe is available in the technical and operational (DTR) documentation in accordance with the catalog number.



Fig. 7

10.5 RS485 wired remote control - for flush mounting

Optionally, the device can be equipped with a wired remote control that allows you to change the operating mode of the device. The remote control housing is made of stainless steel and is designed for flush mounting. The remote control has 3 buttons:

- MODE - allows you to change the operating mode between the standard mode (clock) and the stopwatch / counter / timer (function to be set or in the "TIMERS" tab on the website).
- START/STOP - allows you to start and stop the stopwatch / counter / timer.
- RESET - allows you to reset the stopwatch/counter/timer to the initial values.

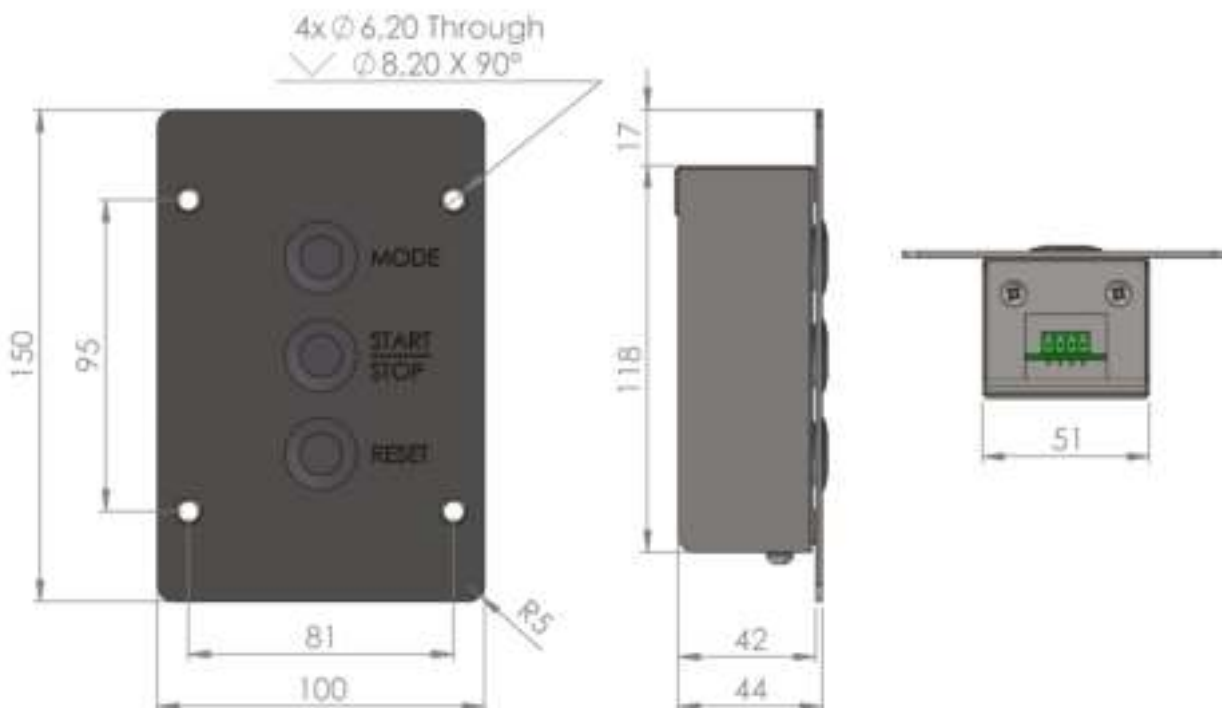

Fig. 8

The remote control is connected to the device with a 4x0.25mm² cable, 5.2m long, terminated with a 4-pin plug. The colors of the remote control cable cores and its connection to the clock control module are shown in the table below:

Table 1

Description of the flush-mounted remote control connectors.	Core color	Notes
A	Yellow	Connect to field A in the control module
B	White	Connect to field B in the control module
GND	Green	Connect to field GND in the control module
5V	Brown	Connect the temperature connectors or the GPS to the 5V field in the control module

10.6 Wireless IR remote control

Optionally, the device may be equipped with a wireless IR remote control. The clock configuration using the remote control is described in Chapter 5.2.1. The remote control is powered by a CR2025 battery.



Fig. 9

11 Initial start-up

Step 1: Connect the device to the mains power supply.

Step 2: A properly connected system should display the factory set (current) time and date.

12 Disposal and recycling

12.1 Packaging material recycling

The packaging elements must be segregated and, then, recycled in accordance with the local executive regulations on waste disposal.

12.2 Device disposal

The device must not be disposed of with normal municipal waste!

In accordance with Directive 2012/19 / EC (WEEE), the user is obliged to transfer the damaged or destroyed device to the appropriate disposal facility if there is no economically justified repair possibility.



13 Most common installation errors

1. The device has not been installed in accordance with the manual.
2. Drilling additional mounting holes in the housing.